

Figure 1: TCD Paddle Layout and Labeling

Thickness Variation among Paddles		
Paddle (See Figure)	Average Thickness (mm)	Variation (mm)
PY1	5.248	0.53
PY2	5.214	0.58
PY3	4.891	0.41
PY4	5.042	0.40
PX1	5.016	0.22
PX2	5.006	0.47
PX3	5.206	0.42
PX4	4.968	0.37

Figure 2: Paddle Thickness Variation

Layer Name	Z Position [cm]	Material	Density [g/cm^3]	Thickness
Top Y-Going Tedlar		Polyvinyl Fluoride	1.73	$76.2\mu m$
Top Y-Going Foil		Aluminum	2.7	$25.4\mu m \pm 2.54\mu m$
Y-Going Scintillator		Polyvinyl Toluene (BC-408)	1.032	$5.05mm \pm 0.37mm$
Bottom Y-Going Foil		Aluminum	2.7	$25.4\mu m \pm 2.54\mu m$
Bottom Y-Going Tedlar		Polyvinyl Fluoride	1.73	$76.2\mu m$
Top X-Going Tedlar		Polyvinyl Fluoride	1.73	$76.2\mu m$
Top X-Going Foil		Aluminum	2.7	$25.4\mu m \pm 2.54\mu m$
X-Going Scintillator		Polyvinyl Toluene (BC-408)	1.032	$5.1mm \pm 0.48mm$
Bottom X-Going Foil		Aluminum	2.7	$25.4\mu m \pm 2.54\mu m$
Bottom X-Going Tedlar		Polyvinyl Fluoride	1.73	$76.2\mu m$
Light Guides	-	Decolorized Methyl Methacrylate Monomer w/UV additives	1.19	-

Table 1: Z-Direction Profile of Materials (Light Guides do not lie in this profile, but their characteristics are presented)

Paddle	A ($\pm 0.635cm$)		B ($\pm 0.4775cm$)		C ($\pm 0.3175cm$)		D ($\pm 0.3175cm$)	E ($\pm 0.1575cm$)
	Plus End	Minus End	Plus End	Minus End	Plus End	Minus End		
PY1	22.86	22.225	3.175	3.81	53.34	53.34	151.194	30.1625
PY2	24.13	24.956	3.4925	2.8575	53.6575	53.975	152.718	30.1625
PY3								
PY4	24.13	24.765	3.175	3.4925	53.34	53.6575	149.543	30.1625
PX1	23.1775	24.13	3.4925	3.175	53.34	53.0225	154.94	30.1625
PX2	22.5425	24.13	3.4925	3.810	54.1325	53.975	154.623	30.1625
PX3	24.4475	25.0825	3.4925	3.810	53.6575	53.34	154.305	30.1625
PX4	23.495	24.13	3.4925	3.4925	53.6575	52.705	152.878	30.1625

Table 2: These have been converted from inches, which were the original units Steve Minick used when he made these measurements

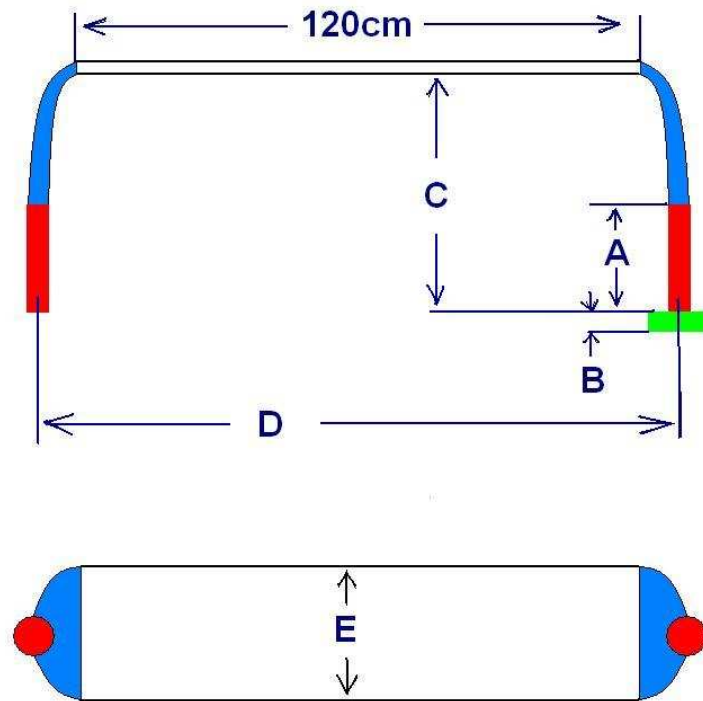

Figure 3: TCD Paddle Dimensions